

Spiralgrip 200

Turntable Stretch Wrapping Machine for up to 25 pallets per hour

High performance, cost effective, easy to use and economic film use

for economically wrapped loads

Power-Pre-Stretch-System

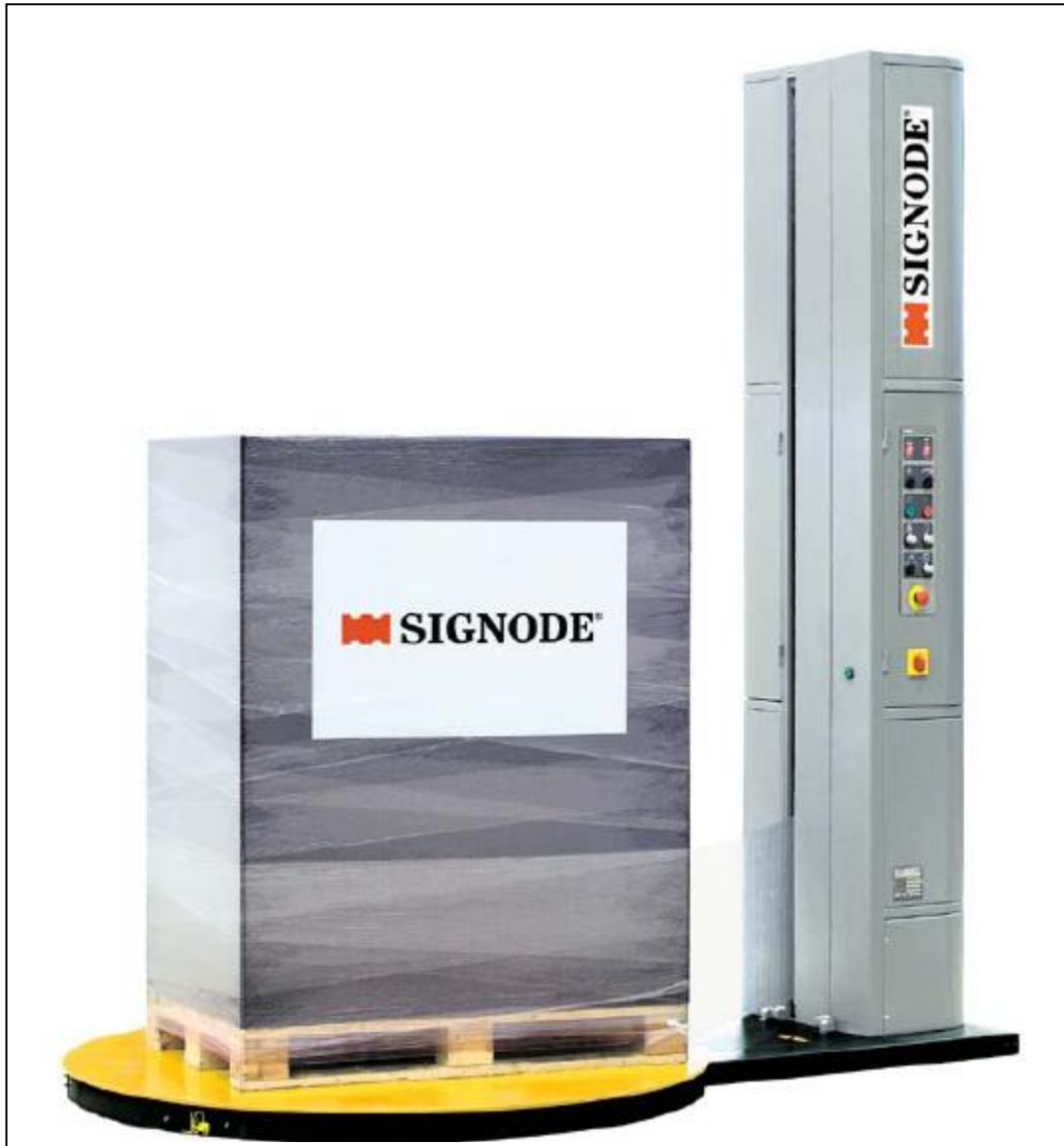

for maximum flexibility & safety

Modular Spiralgrip Concept

Features and Benefits

The Spiralgrip 200 is the first of a new generation of stretch wrapping machines that can offer a PPS or Power Pre-stretch system of 260% with the infinitely variable film-tension control which reduces film costs and usage drastically. Simplicity is the key, all features from installation of the machine, operation, film roll change through to maintenance work are designed for fast, easy and simple execution

Adjustable Programming for maximum productivity and flexibility the load wrapping parameters, film carriage speed, turntable speed, film lay-on tension etc can all be set and adjusted from the integrated control panel. Machine safety is also important, with the film carriage located inside the machine tower, and the interlocked access door makes film loading simple and easy. Operators thus can work efficiently and safely with the machine

The Spiralgrip series is supported by Signode in Europe. Consumables, service and spare parts are readily available, please contact your local SIGNODE partner.

 **SIGNODE**[®]

An ITW Company

MACHINES

SEMI-AUTOMATIC

Spiralgrip 200

Turntable stretch wrapping machine for palletized loads

Easy film reloading by, film roll drop-in system



Efficiency and Simplicity

- Motorized Power-Pre-Stretch-System and minimal film consumption to optimize packaging costs per pallet.
- High productivity Through fast and simple installation, easy maintenance, easy loading and easy feeding of film.

Easy film reloading by, film roll drop-in system



Efficiency

Through motorized power-pre-stretch-system (up to 260 %) and stepless film-tension control.



Easy to use

All machine functions are initiated and controlled via the integrated control panel.

Power Pre-stretch (PPS) - of up to 260%

Technical Data

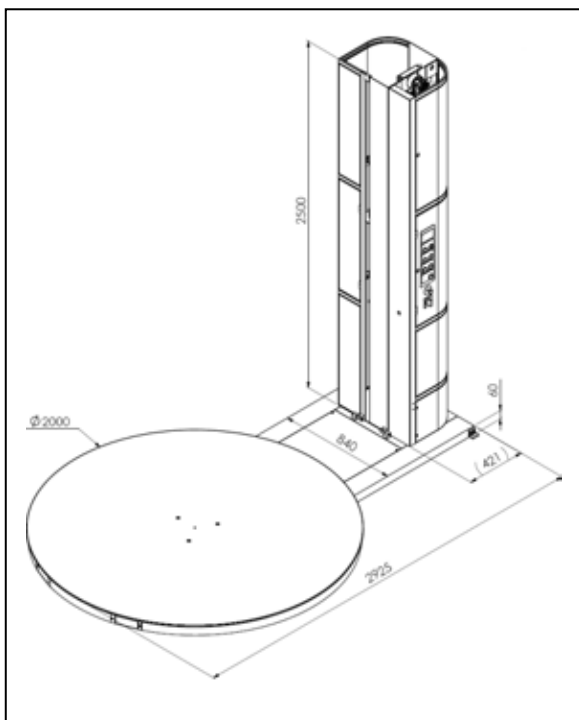

Capacity: 15-25 pallets / hour depending on programme selected and load

Pallet load dimensions (mm)

L x W: max. 1.200 x 1.200
Height: max. 2.200 mm incl pallet
Weight: max. 2.000 kg

Transport dimensions (mm)

L x W x H: 2.600 x 1.800 x 1.200 mm approx.
Weight: 500 kg approx.

Film reel

Width: 500mm
Diameter max: 260mm
Core diameter: 76mm
Film thickness: 17-30µm (for PPS system)
Turntable Ø: 1.650 mm
Turntable height: 80 mm
Turntable speed: Variable from 2 to 12 rpm

Electrical Specification

Power requirement: 0,5 kVA max.
Voltage: 230 V, 1 Ph, 50 Hz
Control Voltage: 24 V DC

Options: Access ramp, 2m diameter turntable, Pit foundation template, load stabilizer

The company reserves the right to make technical changes without prior notification

 **SIGNODE**®

An ITW Company

E-011059

MACHINES

SEMI-AUTOMATIC